

**Components**

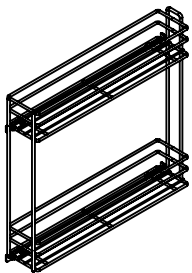

A 1 pc

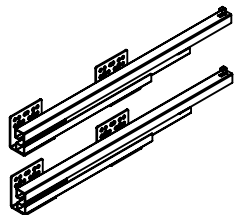

B 1 set

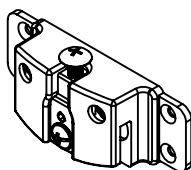

C 2 pcs

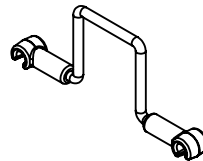

D 3 pcs

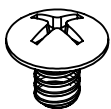

M4\*6  
E 2 pcs

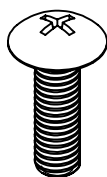

M5\*18  
F 2 pcs



ST4\*14  
G 28 pcs

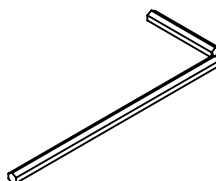

H 1 pc

**Cabinet size (mm)**

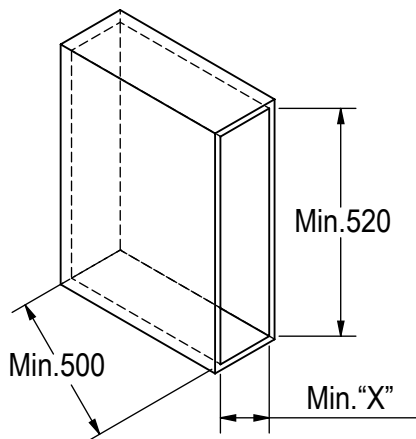

Cabinet size	Product size "X"
150	114
200	164

# Installation

1) Part B = slide position

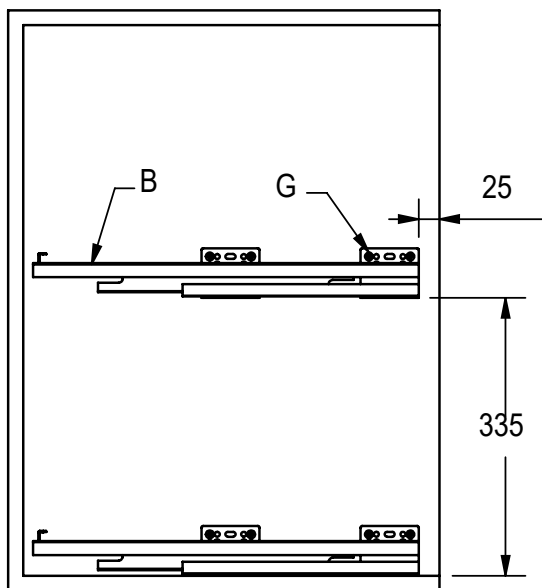

2) Part A = basket assembly position

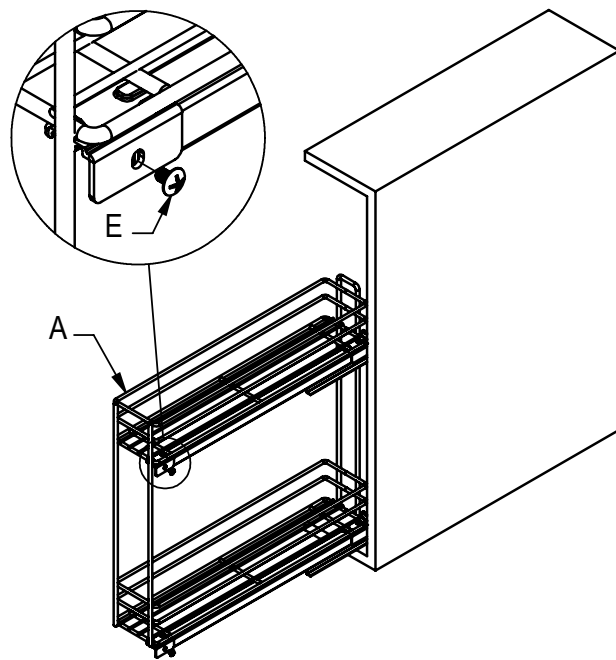

3) Part C = door bracket position

Cabinet width	Product width "X"	Product size "Y"
150	88	31.5
200	128	40.5

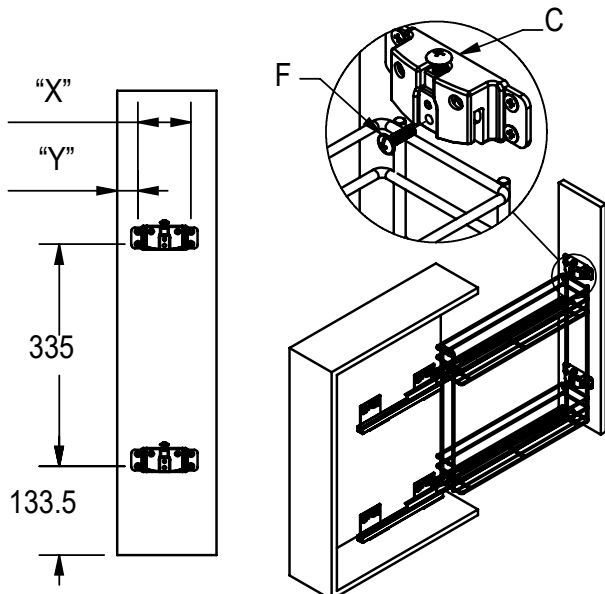

4) Part D = bottle divider position

